



Name _____

	<p>Skill Module Number: 11.2</p> <p>Subject: Ventilation – Solar blower</p>
---	---

Objectives:

At the conclusion of this module, you will be able to:

- Explain the timing and under which circumstances the solar blower system will engage
- List conditions under which the AC CAN is active
- Measure the AC CAN using the HMS 990 scope
- List the conditions under which the 12 V control voltage at the blower regulator is active
- Explain the procedure to indirectly diagnose the solar blower system without the need to access the DC/DC control module

Vehicle and tools required:

- Model 240 with solar panel option
- Solar panels covered up (driver floor protection cardboard)
- Right under dash panel removed
- Multimeter
- Electrical test kit 220 589 00 99 00
- Flashlight
- Maybach vehicle protective covers

Required material:

- Pencil and clipboard
- SDS equipment with 4/03 DAS and HMS 990

Instructions:

1. Follow the instructions and answer the questions
2. Ask your instructor for assistance if needed
3.  means call your instructor for review

The Solar Blower DC \ DC converter control module is not equipped with any self diagnosis or SDS access. The solar panels itself cannot be tested so the best way to diagnose the system is to perform a function test. With its 4 inputs and 2 outputs it is a rather easy system to test, and all without having to access the control unit.

AC CAN

1. Start HMS 990 tester and select universal scope from the menu. Make sure timebase is set to 500 us and the division to 5 V.
2. Unplug the 4 pin AC blower connector located at the bottom of the blower housing. The right under dash panel has already been removed for easier access.
3. Locate AC CAN wire (GN/BU) at pin 4 and connect HMS 990 test lead to it. Ground the black lead at the starter battery terminal.
4. Activate the REST mode at the front AC controller (ignition off). Is the AC CAN active at this point? YES NO
5. Is this the scope pattern you would expect for the climate bus? YES NO
6. Turn Ignition on but do not turn the AC system on. Is the AC CAN active at this point? YES NO
7. Turn Ignition off. Is the AC CAN still active? YES NO
8. Sit in vehicle and time after run period of the AC CAN. Turn ignition on and off to start the timer. How long does the AC CAN stay active after ignition off?

9. Did you hear the flap actuator motors being activated to their rest positions just before the AC CAN shut down? YES NO



Instructor check point _____

Control line

1. Locate control voltage wire (WH/YE) at pin 2 and connect multimeter test lead to it. Ground the black lead at the starter battery terminal. Leave the HMS 990 connected to the AC CAN line for reference.
2. What is the voltage level on this line with ignition off and solar panels covered?
_____ Volts
3. Turn Ignition on. What is the voltage level now? _____ Volts
4. Turn Ignition off. Does the voltage level change immediately? YES NO
5. Observe the voltage reading as well as the scope pattern. What did you hear from the left under dash area at the moment the voltage dropped?

6. Did the control line shut down together with the AC CAN? YES NO
7. Activate the REST mode at the front AC controller (ignition off). Did the control voltage go back up to 12 volt? YES NO
8. Deactivate REST mode. The control voltage is supplied by the AC or the solar generator control module. On the attached wiring diagram locate pin 2 of the blower regulator. What other component of the solar blower system is activated by this 12 V control signal? _____

Note: The AC CAN line is not an input to the solar generator module, yet it is a clear indicator of when the control voltage should shut down, which is an input.

9. The Solar generator control module houses the separation/selection relay which will select the power source for the blower motor. In which operation mode (battery or solar) is this relay activated (energized)? _____

Note: This is the component you heard click the moment the voltage dropped!

10. Could this relay be responsible for an inoperative AC blower? YES NO
11. The voltage reading should be near 0 volts. Watch the voltage meter while someone uncovers the solar panels. Was there a voltage spike the moment the panels were uncovered? YES NO
12. What is the voltage reading with the solar panels uncovered? _____ V

Note: Under the sun this line needs to read 12 volts for the solar blower system to engage. This is not the load line to the blower however, very low amperage.

13. Taking these tests into account what conclusion can you make regarding the operating conditions of the solar blower system and diagnostic steps?

Note: The voltage generating capability of the cells can only be tested in sun.



Instructor check point _____

Blower power supply

1. Locate power supply (RD/YE) wire at pin 3 and connect Multimeter test lead to it. Ground the black lead at the starter battery terminal .
2. What is the present voltage level on this line with ignition off? _____ V
3. Turn ignition on. What is the voltage level on this line now? _____ V
4. What conclusion can you make regarding the functionality of the separation/selection relay inside the DC/DC converter? _____

5. Turn ignition off and wait until the AC CAN and control voltage are shut down.
6. Shortly after the control voltage drops the solar generator control module will initiate a soft start of the blower power supply if sufficient solar energy is provided. This is the only way to test the solar panels and the DC/DC converter itself.

Note: Compared to the battery power mode, the solar power mode regulates both voltage and amperage to the maximum possible. This will generally be far below 12 volts when under blower load.

7. Put cover back on solar panels

8. Connect SDS to vehicle and erase all fault codes. Return all tools and vehicle to their original condition. Call your instructor for review.



Instructor check point _____

If you have noticed any parts that need to be replaced on this vehicle, please inform your instructor now.

Automatic Air Conditioning, solar blower

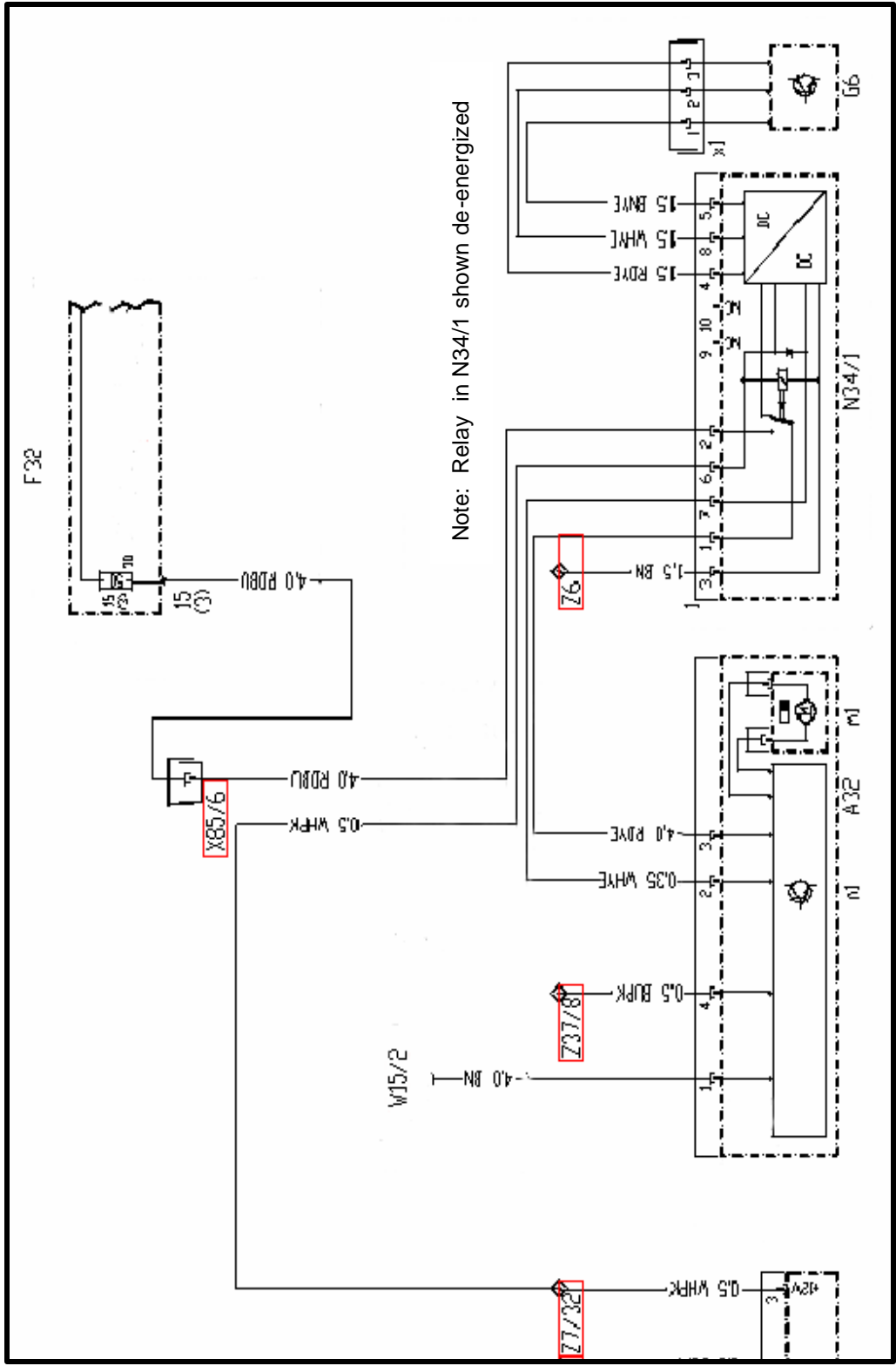

A32	AC recirculation unit	G6	Solar cells
A32m1	Blower motor	G6x1	Solar cell connector
A32n1	Blower regulator	N34/1	Solar generator control module
F32	Front prefuse	W15/2	Ground (left footwell)
F32F15	Fuse 15	X85/6	AAC [KLA]/cockpit connector
		Z6	Ground connector sleeve
		Z7/32	Circuit 30 connector sleeve (Control voltage)
		Z37/8	CAN bus climate control connector sleeve